

Max Frame	DP Rating	Impact
37 1/2" x 80 3/4"	+65/-70	YES

Installed Fastener Schedule:

1. Seal flange/frame to substrate.
2. Use #12 PH or greater fasteners through frame with sufficient length to penetrate a minimum of 1 1/2" into the wood framing. For 2X wood frame substrate (min. S.G. = 0.42).
3. Install corrosion resistant 1-#8 X 2" screws through each hinge into rough opening.
4. Install corrosion resistant 2-#8 X 2" screws through each strike plate into rough opening.
5. Host structure (wood buck, stud framing and opening) to be designed and anchored to properly transfer all loads to the structure. The host structure is the responsibility of the architect or engineer of record for the project of installation.

General Notes:

1. The product shown herein is designed, tested and manufactured to comply with the wind load criteria of the adopted International Building Code (IBC), the International Residential Code (IRC), the Florida Building Code (FBC) excluding HVHZ and the industry standard requirement for the stated conditions.
2. Buck, framing and masonry by others and is responsibility of architect or engineer of record.
3. All glazing shall conform to ASTM E1300.
4. At minimum, glazing shall be 6.35mm tempered - 7.36mm airspace - 4.7mm annealed - 2.29mm PVB Interlayer by Dupont - 4.7mm annealed insulating glass.

This schedule addresses only the fasteners required to anchor the window to achieve the rated design pressure up to the size limitations noted. It is not intended as a guide to the installation process and does not address the sealing consideration that may arise in different wall conditions. For the complete installation procedure, see the instructions packaged with the door or go to www.jeld-wen.com.

DISCLAIMER:

This drawing and its contents are confidential and are not to be reproduced or copied in whole or in part or used or disclosed to others except as authorized by JELD-WEN Inc.

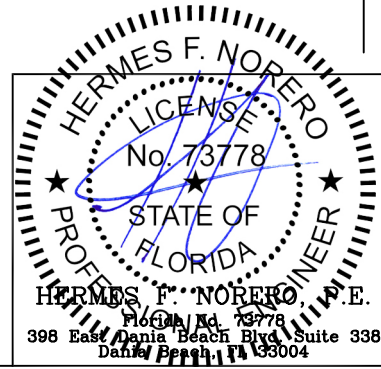

PROJECT ENGINEER: ---	DATE: 01/03/2018	JELD WEN	3737 Lakeport Blvd Klamath Falls, OR. 97601 Phone: (800) 535-3936	
DRAWN BY: D. Vezo	SCALE: NTS			
CHECKED BY: J. Hawkins	TITLE: Architectural Fiberglass Glazed Outswing Impact Door			
APPROVED BY: D. Vezo	PART/PROJECT No.:			
	D014771			
IDENTIFIER No. TEL 01681715	PLANT NAME AND LOCATION: ----	CAD DWG. No.:	REV:	SHEET

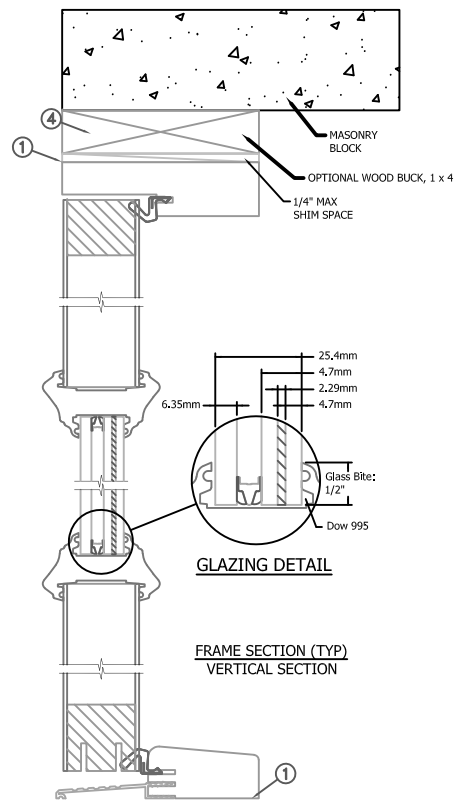
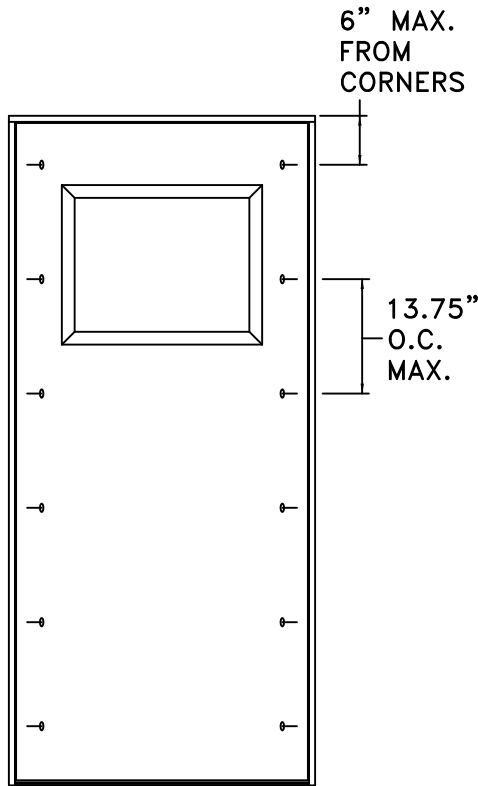

**THROUGH FRAME
INSTALLATION**

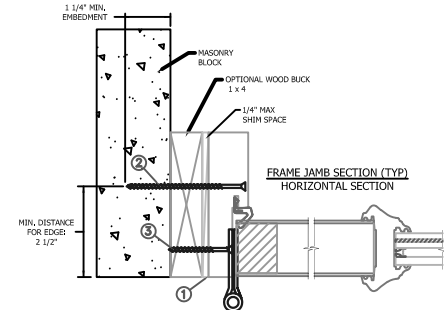
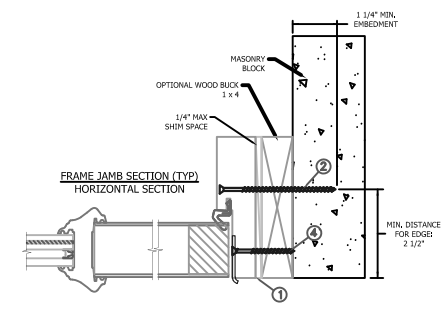

Max Frame	DP Rating	Impact
37 1/2" x 80 3/4"	+65/-70	YES

Installed Fastener Schedule:

1. Seal flange/frame to substrate.
2. Use 3/16" Tapcon or equivalent fasteners through frame with sufficient length to penetrate a minimum of 1 1/4" into concrete or masonry at each location with a 2 1/2" min. from edge distance. For concrete (min. fc = 3000 psi) or masonry substrate (min fc = 2000psi) (CMU shall adhere to ASTM C90).
3. Install corrosion resistant 1-#8 X 2" screws through each hinge into rough opening.
4. Install corrosion resistant 2-#8 X 2" screws through each strike plate into rough opening.
5. Host structure (wood buck, stud framing and opening) to be designed and anchored to properly transfer all loads to the structure. The host structure is the responsibility of the architect or engineer of record for the project of installation.

General Notes:

1. The product shown herein is designed, tested and manufactured to comply with the wind load criteria of the adopted International Building Code (IBC), the International Residential Code (IRC), the Florida Building Code (FBC) excluding HVHZ and the industry standard requirement for the stated conditions.
2. Buck, framing and masonry by others and is responsibility of architect or engineer of record.
3. All glazing shall conform to ASTM E1300.
4. At minimum, glazing shall be 6.35mm tempered - 7.36mm airspace - 4.7mm annealed - 2.29mm PVB Interlayer by Dupont - 4.7mm annealed insulating glass.

This schedule addresses only the fasteners required to anchor the window to achieve the rated design pressure up to the size limitations noted. It is not intended as a guide to the installation process and does not address the sealing consideration that may arise in different wall conditions. For the complete installation procedure, see the instructions packaged with the door or go to www.jeld-wen.com.

DISCLAIMER:

This drawing and its contents are confidential and are not to be reproduced or copied in whole or in part or used or disclosed to others except as authorized by JELD-WEN Inc.

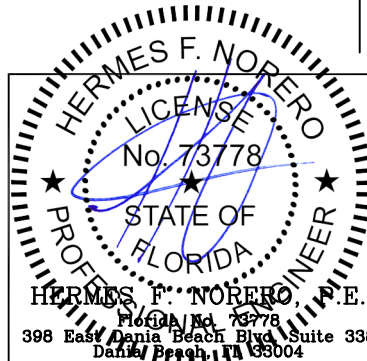

PROJECT ENGINEER: ---	DATE: 01/03/2018	JELD-WEN 3737 Lakeport Blvd Klamath Falls, OR. 97601 Phone: (800) 535-3936
DRAWN BY: D. Vezo	SCALE: NTS	
CHECKED BY: J. Hawkins	TITLE: Architectural Fiberglass Glazed Outswing Impact Door	
APPROVED BY: D. Vezo		
PART/PROJECT No.:		
D014771		
IDENTIFIER No. TEL 01681715	PLANT NAME AND LOCATION: ----	CAD DWG. No.:
		REV:
		SHEET

MASONRY STRAP INSTALLATION

6" MAX.
FROM
CORNERS

13.75"
O.C.
MAX.

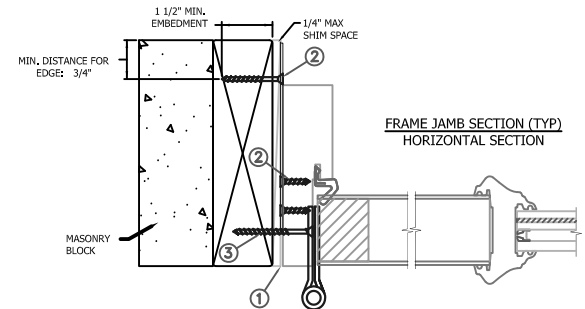
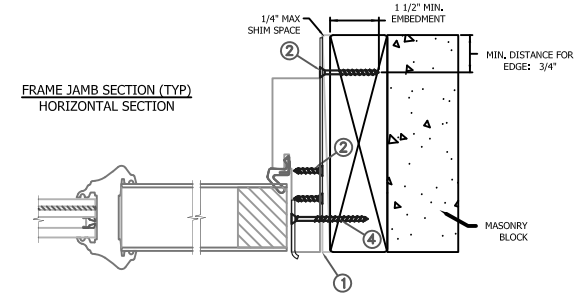
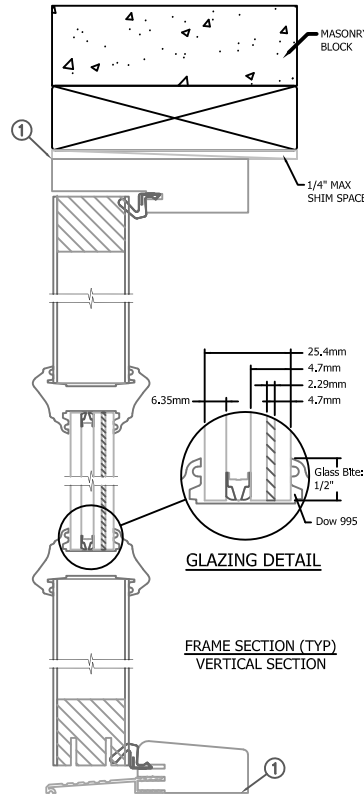
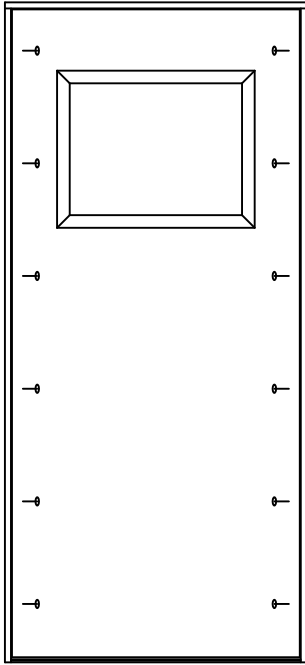

Max Frame	DP Rating	Impact
37 1/2" x 80 3/4"	+65/-70	YES

Installed Fastener Schedule:

1. Seal flange/frame to substrate.
2. Install masonry straps to wood frame using #8 corrosion resistant fasteners no more than 6" from each corner and 13.75" o.c. along the jambs and head. Bend straps around buck and secure with #8 fastener thru masonry strap into buck. Fasteners must be long enough to penetrate at least 1" into framing members.
3. Install corrosion resistant 1-#8 X 2" screws through each hinge into rough opening.
4. Install corrosion resistant 2-#8 X 2" screws through each strike plate into rough opening.
5. Host structure (wood buck, stud framing and opening) to be designed and anchored to properly transfer all loads to the structure. The host structure is the responsibility of the architect or engineer of record for the project of installation.

This schedule addresses only the fasteners required to anchor the window to achieve the rated design pressure up to the size limitations noted. It is not intended as a guide to the installation process and does not address the sealing consideration that may arise in different wall conditions. For the complete installation procedure, see the instructions packaged with the door or go to www.jeld-wen.com.

DISCLAIMER:

This drawing and its contents are confidential and are not to be reproduced or copied in whole or in part or used or disclosed to others except as authorized by JELD-WEN Inc.

General Notes:

1. The product shown herein is designed, tested and manufactured to comply with the wind load criteria of the adopted International Building Code (IBC), the International Residential Code (IRC), the Florida Building Code (FBC) excluding HVHZ and the industry standard requirement for the stated conditions.
2. Buck, framing and masonry by others and is responsibility of architect or engineer of record.
3. All glazing shall conform to ASTM E1300.
4. At minimum, glazing shall be 6.35mm tempered - 7.36mm airspace - 4.7mm annealed - 2.29mm PVB Interlayer by Dupont - 4.7mm annealed insulating glass.

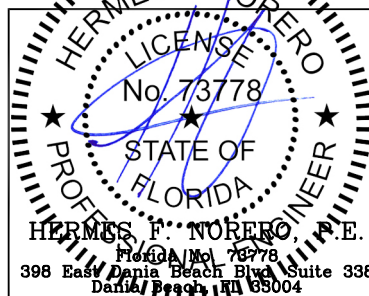

PROJECT ENGINEER: ---	DATE: 01/03/2018	JELD-WEN	3737 Lakeport Blvd Klamath Falls, OR. 97601 Phone: (800) 535-3936		
DRAWN BY: D. Vezo	SCALE: NTS				
CHECKED BY: J. Hawkins	TITLE: Architectural Fiberglass Glazed Outswing Impact Door				
APPROVED BY: D. Vezo	PART/PROJECT No.:				
	D014771				
IDENTIFIER No. TEL 01681715	PLANT NAME AND LOCATION: ----	CAD DWG. No.:	REV:	SHEET	

6" MAX.
FROM
CORNERS

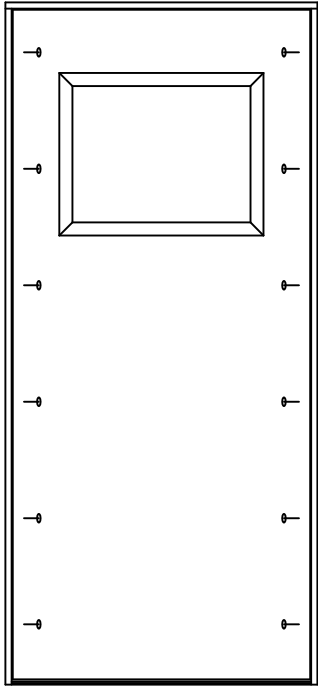

13.75"
O.C.
MAX.

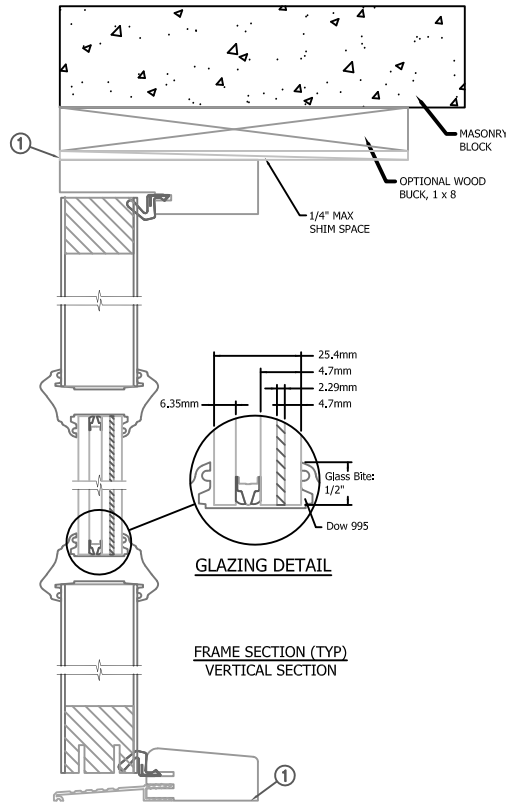

MASONRY STRAP INSTALLATION

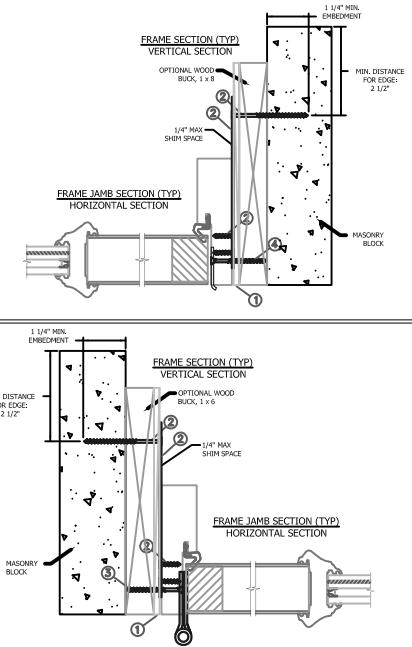

Max Frame	DP Rating	Impact
37 1/2" x 80 3/4"	+65/-70	YES

Installed Fastener Schedule:

1. Seal flange/frame to substrate.
2. Use 3/16" Tapcon or equivalent fasteners through strap with sufficient length to penetrate a minimum of 1 1/4" into concrete or masonry at each location with a 2 1/2" min. from edge distance. 2-#8 x 1/2" PH screws through the strap into frame. For concrete (min. fc = 3000 psi) or masonry substrate (min fc = 2000psi) (CMU shall adhere to ASTM C90).
3. Install corrosion resistant 1-#8 X 2" screws through each hinge into rough opening.
4. Install corrosion resistant 2-#8 X 2" screws through each strike plate into rough opening.
5. Host structure (wood buck, stud framing and opening) to be designed and anchored to properly transfer all loads to the structure. The host structure is the responsibility of the architect or engineer of record for the project of installation.

General Notes:

1. The product shown herein is designed, tested and manufactured to comply with the wind load criteria of the adopted International Building Code (IBC), the International Residential Code (IRC), the Florida Building Code (FBC) excluding HVHZ and the industry standard requirement for the stated conditions.
2. Buck, framing and masonry by others and is responsibility of architect or engineer of record.
3. All glazing shall conform to ASTM E1300.
4. At minimum, glazing shall be 6.35mm tempered - 7.36mm airspace - 4.7mm annealed - 2.29mm PVB Interlayer by Dupont - 4.7mm annealed insulating glass.

This schedule addresses only the fasteners required to anchor the window to achieve the rated design pressure up to the size limitations noted. It is not intended as a guide to the installation process and does not address the sealing consideration that may arise in different wall conditions. For the complete installation procedure, see the instructions packaged with the door or go to www.jeld-wen.com.

DISCLAIMER:

This drawing and its contents are confidential and are not to be reproduced or copied in whole or in part or used or disclosed to others except as authorized by JELD-WEN Inc.

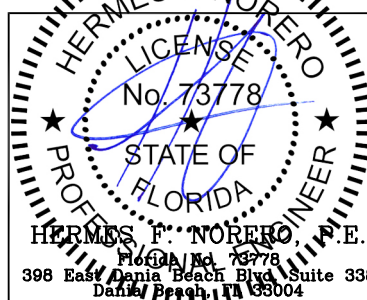

PROJECT ENGINEER: ---	DATE: 01/03/2018	JELD-WEN	3737 Lakeport Blvd Klamath Falls, OR. 97601 Phone: (800) 535-3936	
DRAWN BY: D. Vezo	SCALE: NTS			
CHECKED BY: J. Hawkins	TITLE: Architectural Fiberglass Glazed Outswing Impact Door			
APPROVED BY: D. Vezo				
PART/PROJECT No.: D014771				
IDENTIFIER No. TEL 01681715	PLANT NAME AND LOCATION: ----	CAD DWG. No.:	REV:	SHEET

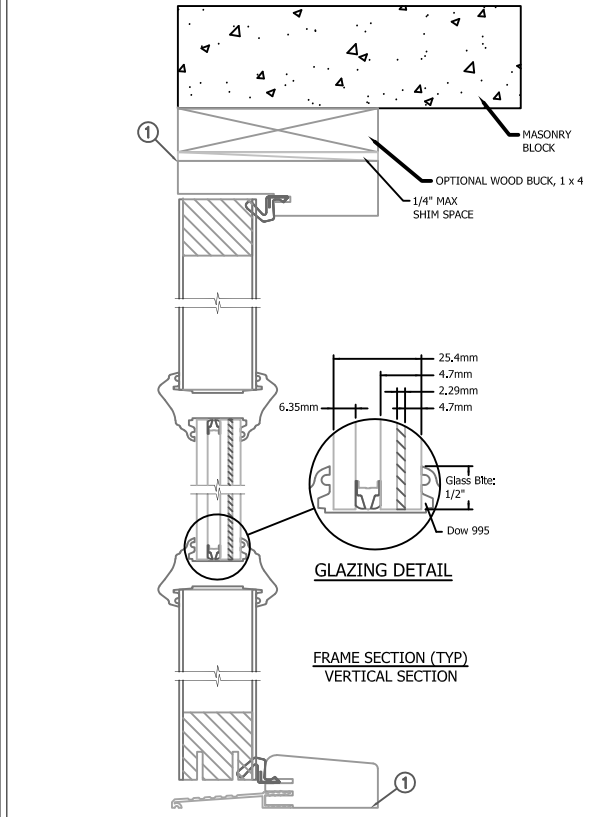
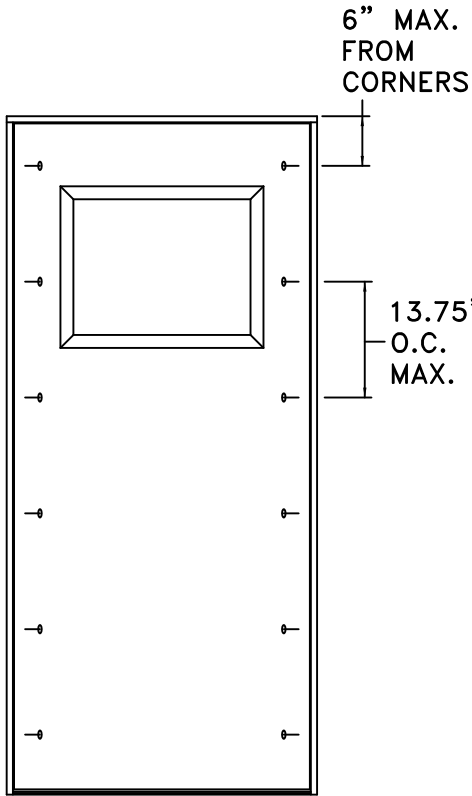

MASONRY STRAP INSTALLATION

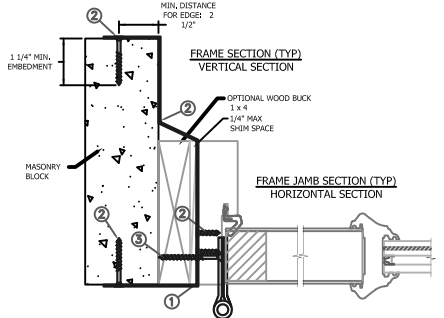
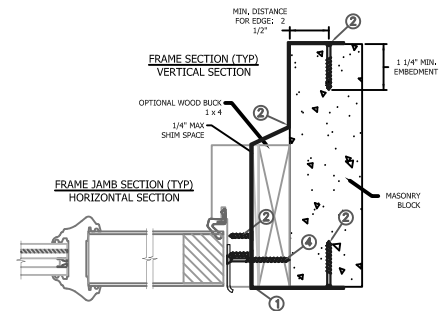

Max Frame	DP Rating	Impact
37 1/2" x 80 3/4"	+65/-70	YES

Installed Fastener Schedule:

1. Seal flange/frame to substrate.
2. Use 3/16" Tapcon or equivalent fasteners through the interior and exterior of the strap with sufficient length to penetrate a minimum of 1 1/4" into concrete or masonry at each location with a 2 1/2" min. from edge distance. 2-#8 x 1/2" PH screws through the strap into frame. For concrete (min. fc = 3000 psi) or masonry substrate (min fc = 2000psi) (CMU shall adhere to ASTM C90).
3. Install corrosion resistant 1-#8 X 2" screws through each hinge into rough opening.
4. Install corrosion resistant 2-#8 X 2" screws through each strike plate into rough opening.
5. Host structure (wood buck, stud framing and opening) to be designed and anchored to properly transfer all loads to the structure. The host structure is the responsibility of the architect or engineer of record for the project of installation.

General Notes:

1. The product shown herein is designed, tested and manufactured to comply with the wind load criteria of the adopted International Building Code (IBC), the International Residential Code (IRC), the Florida Building Code (FBC) excluding HVHZ and the industry standard requirement for the stated conditions.
2. Buck, framing and masonry by others and is responsibility of architect or engineer of record.
3. All glazing shall conform to ASTM E1300.
4. At minimum, glazing shall be 6.35mm tempered - 7.36mm airspace - 4.7mm annealed - 2.29mm PVB Interlayer by Dupont - 4.7mm annealed insulating glass.

This schedule addresses only the fasteners required to anchor the window to achieve the rated design pressure up to the size limitations noted. It is not intended as a guide to the installation process and does not address the sealing consideration that may arise in different wall conditions. For the complete installation procedure, see the instructions packaged with the door or go to www.jeld-wen.com.

DISCLAIMER:

This drawing and its contents are confidential and are not to be reproduced or copied in whole or in part or used or disclosed to others except as authorized by JELD-WEN Inc.

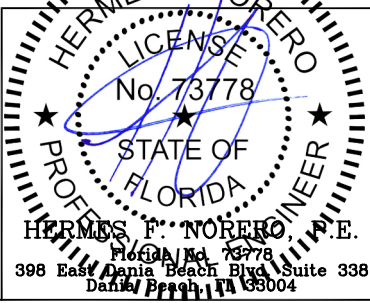

PROJECT ENGINEER: ---	DATE: 01/03/2018	JELD-WEN	3737 Lakeport Blvd Klamath Falls, OR. 97601 Phone: (800) 535-3936	
DRAWN BY: D. Vezo	SCALE: NTS			
CHECKED BY: J. Hawkins	TITLE: Architectural Fiberglass Glazed Outswing Impact Door			
APPROVED BY: D. Vezo				
PART/PROJECT No.: D014771				
IDENTIFIER No. TEL 01681715	PLANT NAME AND LOCATION: ----	CAD DWG. No.:	REV:	SHEET

6" MAX.
FROM
CORNERS

13.75"
O.C.
MAX.

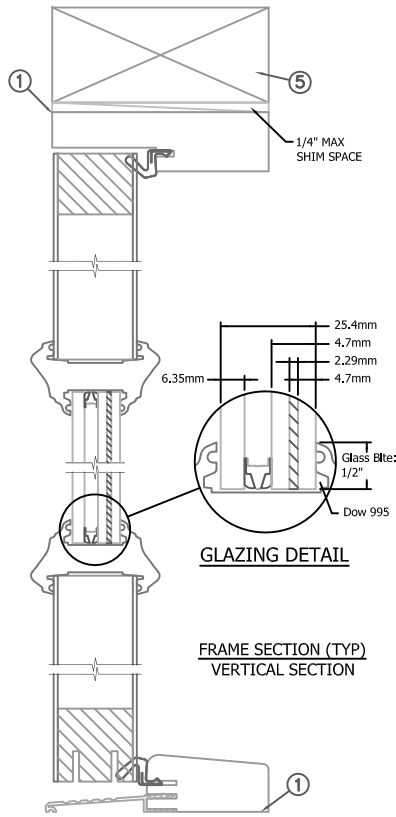
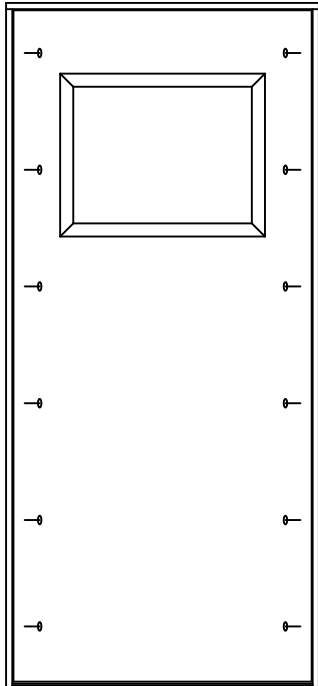

GLAZING DETAIL

FRAME SECTION (TYP)
VERTICAL SECTION

MASONRY STRAP
INSTALLATION

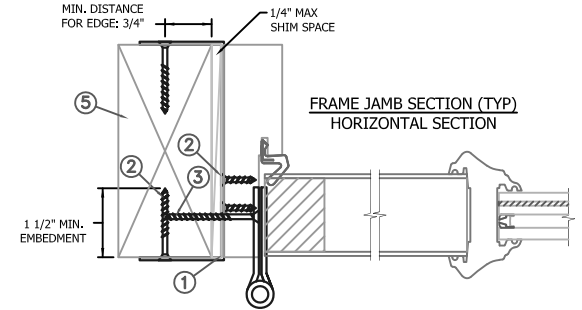
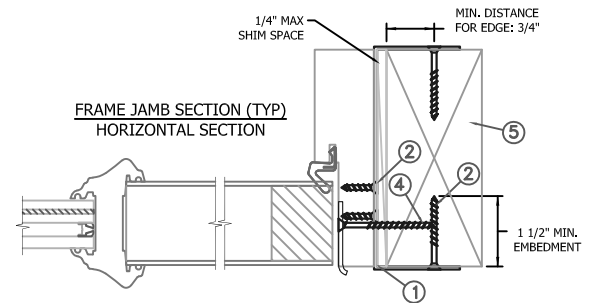

Max Frame	DP Rating	Impact
37 1/2" x 80 3/4"	+65/-70	YES

Installed Fastener Schedule:

1. Seal flange/frame to substrate.
2. Install masonry straps to wood frame using #8 corrosion resistant fasteners no more than 6" from each corner and 13.75" o.c. along the jambs and head. Bend straps around buck to the interior and exterior, and secure with #8 fastener thru masonry strap into buck. Fasteners must be long enough to penetrate at least 1 1/2" into framing members. Minimum specific gravity = (Min. S.G. = 0.42).
3. Install corrosion resistant 1-#8 X 2" screws through each hinge into rough opening.
4. Install corrosion resistant 2-#8 X 2" screws through each strike plate into rough opening.
5. Host structure (wood buck, stud framing and opening) to be designed and anchored to properly transfer all loads to the structure. The host structure is the responsibility of the architect or engineer of record for the project of installation.

General Notes:

1. The product shown herein is designed, tested and manufactured to comply with the wind load criteria of the adopted International Building Code (IBC), the International Residential Code (IRC), the Florida Building Code (FBC) excluding HVHZ and the industry standard requirement for the stated conditions.
2. Buck, framing and masonry by others and is responsibility of architect or engineer of record.
3. All glazing shall conform to ASTM E1300.
4. At minimum, glazing shall be 6.35mm tempered - 7.36mm airspace - 4.7mm annealed - 2.29mm PVB Interlayer by Dupont - 4.7mm annealed insulating glass.

This schedule addresses only the fasteners required to anchor the window to achieve the rated design pressure up to the size limitations noted. It is not intended as a guide to the installation process and does not address the sealing consideration that may arise in different wall conditions. For the complete installation procedure, see the instructions packaged with the door or go to www.jeld-wen.com.

DISCLAIMER:

This drawing and its contents are confidential and are not to be reproduced or copied in whole or in part or used or disclosed to others except as authorized by JELD-WEN Inc.

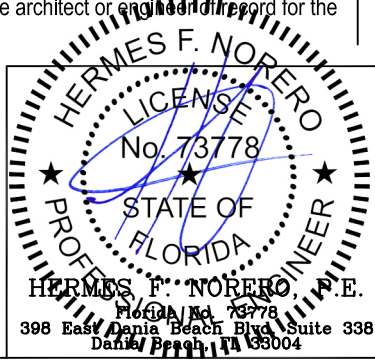

PROJECT ENGINEER: ---	DATE: 01/03/2018	JELD-WEN	3737 Lakeport Blvd Klamath Falls, OR. 97601 Phone: (800) 535-3936	
DRAWN BY: D. Vezo	SCALE: NTS			
CHECKED BY: J. Hawkins	TITLE: Architectural Fiberglass Glazed Outswing Impact Door			
APPROVED BY: D. Vezo	PART/PROJECT No.:			
	D014771			
IDENTIFIER No. TEL 01681715	PLANT NAME AND LOCATION: ----	CAD DWG. No.:	REV:	SHEET